

SCHOTTKY DIODES KDS 2131A. PRELIMINARY

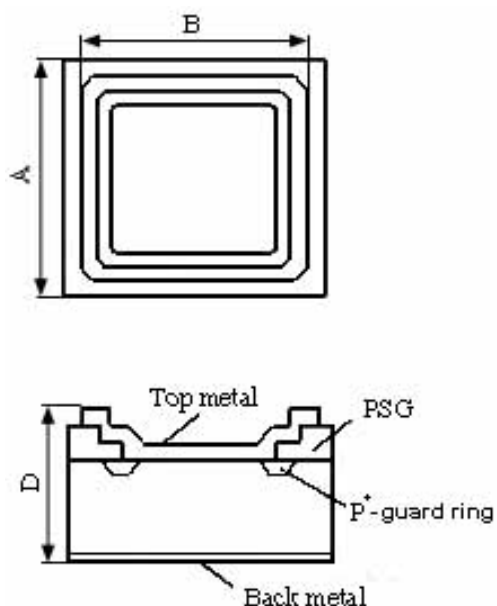

Rev.1. Feb. 2010

 VSP-MIKRON	20A/15V. Die Size-106*158mil.			
Electrical Characteristics	Symbol	Unit	Spec. limit	Die Sort
Breakdown Voltage @ $I_R=10mA$	V_{BR}	V	18	20
Average Rectified Forward Current	$I_{F(AV)}$	A	20,0	-
DC Forward Voltage @ 25°C, $I_F=20,0A$	V_F	V	0,37	0,36 (0,34-typ)
Maximum Reverse Current @ 25°C, $V_R=15V$ 25°C, $V_R=18V$ 100°C, $V_R=15V$	I_R	mA	15,0 - 500,0	10,0 13,0 450,0
Peak Forward Surge Current 8,3ms single half sine-wave superimposed on rated load (JEDEC METHOD)	I_{FSM}	A	300	-
Peak Repetitive Reverse Surge Current @2,0µs, f=1kHz., $T_J<125°C$.	I_{RRM}	A	5,0	
Electrostatic Discharge Voltage. JEDEC Method. ESD HBM. Contact.	ESD	kV	±8 (contact)	
Voltage Rate of Change	dV/dt	V/µS	10.000	
Operating Junction Temperature	T_J	°C	125	



DIM	ITEM	µm
A_x A_y	Wafer Form Die Size	4000 2700
B_x B_y	Top Metal Size	3820 2520
D	Thickness	350max.
Scribe line Width		80

Top metal: a) **Al** – for Wire Bonding;
b) **Al-Ni-Ag** – for Soldering.
Backside metal: **Ti-Ni-Ag**.